

Stratos[®] Miera[™] 25

LOCALISED ASPIRATING SMOKE DETECTOR



Key Features

- Ultra small low cost aspirating smoke detector for easy and discreet installation.
- High sensitivity provided by laser based forward light scatter for reliable early warning.
- Single sampling pipe up to 50m in length (still air).
- Unique ClassiFire[®] Perceptive Artificial Intelligence system that dynamically adjusts the detector's operating parameters, allowing for day to day changes in the protected environment and dust separation system contamination.
- Unwanted alarms from dust are avoided using patented Dual Technology LDD 3D³ Laser Dust Discrimination and elimination system.
- RS485 communications built in as standard for networking and remote communications.

Description

Stratos-Miera 25 is designed to provide very high sensitivity smoke detection in a small package.

ClassiFire Perceptive Artificial Intelligence ensures that the detector operates at optimum sensitivity for the protected environment, without the need for complex setup. This means the product will configure itself to provide high sensitivity in a computer room or reduced sensitivity in a smoky area.

The detector is designed to fit into a Docking Station. All sampling pipes and cables are connected to the Docking Station as a first fix operation leaving the detector to be fitted during the final commissioning phase if required. This ensures that detectors are less likely to be damaged during the installation.

Upgradable volt-free Fire and Fault relay outputs are available for remote monitoring by local fire detection or BMS systems.

Applications & Acceptance

Stratos detectors have been successfully applied in tens of thousands of applications worldwide, ranging from Clean Rooms to Casinos.

Options Available

- Addressable Protocol Interface Cards APIC[™] available for most popular industry signalling protocols.
- Command Module available for central monitoring and display.
- SenseNet compatible - up to 127 detectors per loop.
- Remote Display units available.
- Suitable for Stratos-MatrixScan, a patented software system which provides virtual addressable location detection - e.g. 10 physical detectors would provide up to 45 unique addressable locations.

Approvals

- Approved/listed by most major international fire protection certification agencies. (contact AirSense Technology for latest details)

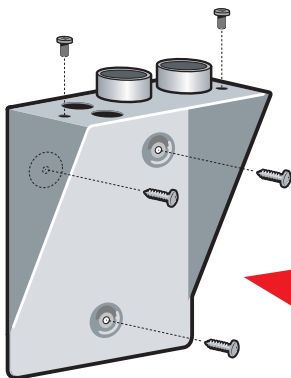

Stratos-Miera 25 detectors are able to be mounted in either 'standard' or 'piped exhaust' type Docking Stations as required by the installation.



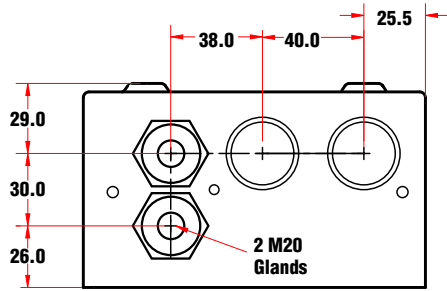

Dimensions of piped exhaust docking station

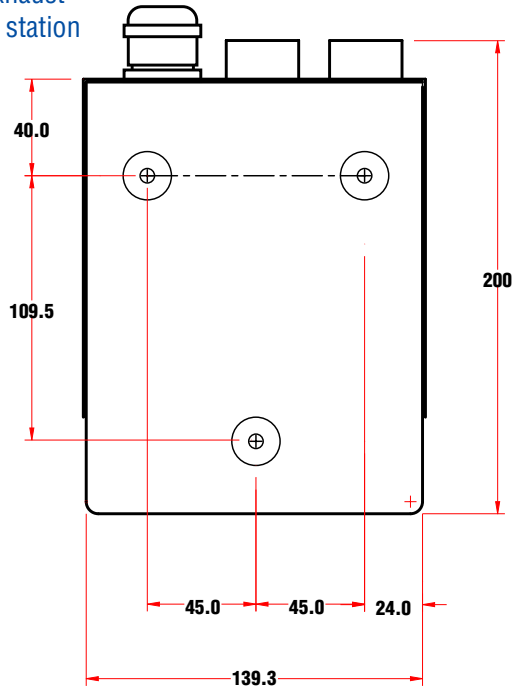

Leave 80mm clearance at top and bottom of docking station for access

SPECIFICATIONS Stratos-Micra 25

Supply Voltage	21.6V - 26.4V DC
Current consumption	250mA @ 24V DC
Size	140W x 200H x 85D
Weight	1.7kg
Operating temperature range	-10 to +38°C (UL268) -10 to + 60°C (CEA4022)
Operating humidity range	0 - 90% non-condensing
Measurement range (%Obs/m)	0.0015% to 25%
Maximum display resolution	0.0015% obscuration per metre
Detection principle	Laser light scattering mass detection and particle evaluation
Particle sensitivity range	0.003µ to 10µ
Dust discrimination principle	3D ³ Laser Dust Discrimination (LDD)
Recommended max. sampling pipe length	25m moving air 50m still air
Sampling pipe diameter	3/4" nominal bore (27mm O/D)
Recommended no. sampling holes	10
Alarm levels	4 (Aux, Pre-alarm, Fire 1 and Fire 2)
Laser chamber service intervals	Greater than 10 years (dependent on environment)
Laser lifetime (MTTF)	Greater than 1000 years
Programming	Command Module or PC via RS232/RS485
Network data bus	RS485
Maximum total data bus length	1.2 km
IP rating	IP50
Sampling pipe inlets	1
Exhaust air pipe outlets	1 on optional Piped Exhaust docking station

ORDERING INFORMATION

Part No.	Description
30750	Stratos-Micra 25 Detector Module
30752	Docking Station (standard exhaust)
30753	Docking Station (piped exhaust)
30436	Relay Input PCB
30755	Replacement Filter
30240	Setup and servicing Software (free of charge)
30419	Serial PC Lead
30821	PS25 Power Supply

APPLICATIONS

- Data storage units
- Air duct protection
- Prison cells
- Heritage property protection
- Plant rooms
- Critical equipment
- Air conditioning units
- Anti-smoking enforcement
- Equipment racks
- Motor rooms
- Computer rooms



AirSense Technology Limited

1 Caxton Place • Caxton Way • Stevenage • Herts • SG1 2UG • UK

Tel: +44(0)1438 751296 • Fax: +44(0)1438 729137

e-mail: sales@airsense.co.uk • www.airsensetechnology.com

AirSense Technology Limited (Hong Kong)

1801 Wing On Central Building • 26 Des Voeux Road Central • Central Hong Kong

Tel: (852) 2961 4206 • Fax: (852) 3007 4737

e-mail: kevin.hui@airsense.co.uk



Quality system cert. no. 404
Assessed to ISO 9001:2000